

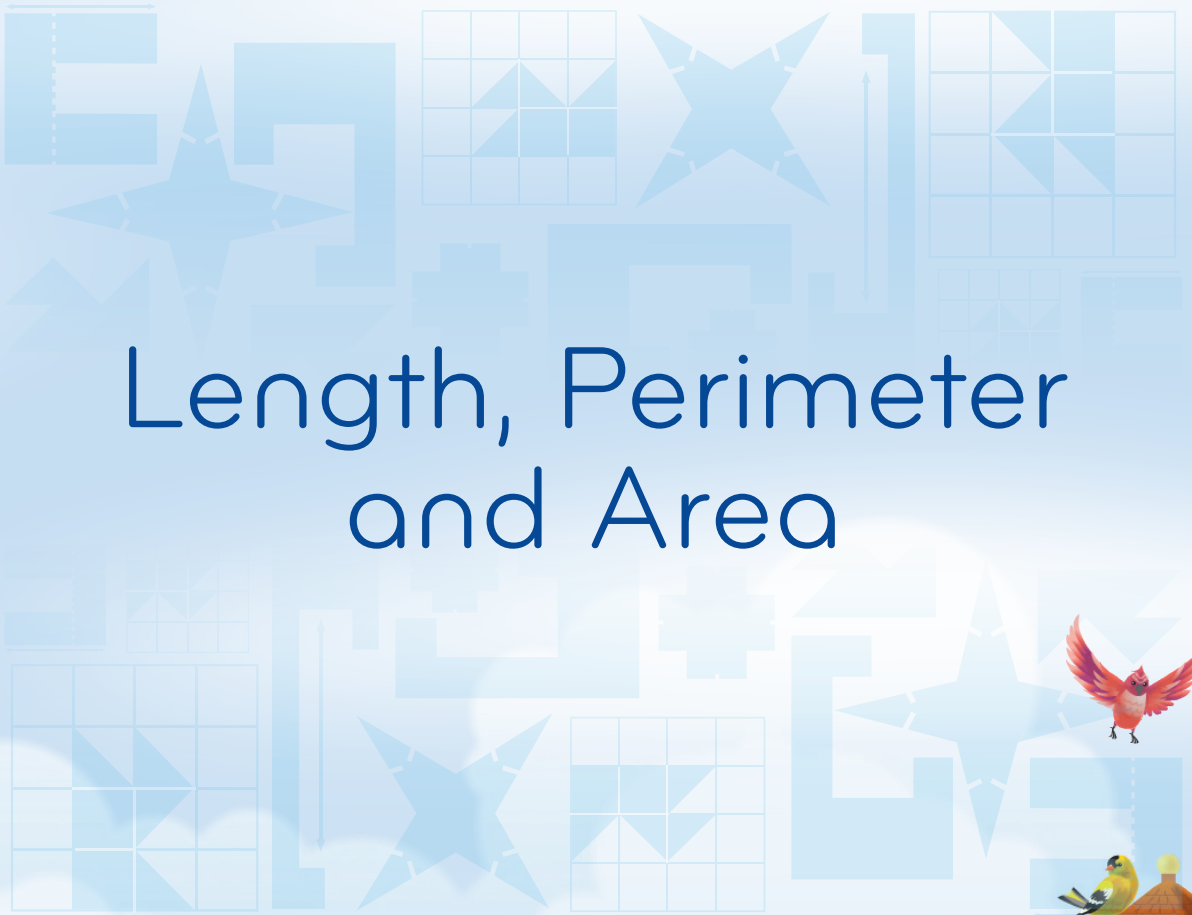

Series **F** Teacher 



# Length, Perimeter and Area



# Series F – Length, Perimeter and Area

## Contents

Student book answers _____	1
Assessment _____	4
Student progress record _____	9
Assessment answers _____	10
Objectives _____	11

Series Authors:

Rachel Flenley  
Nicola Herringer

# Series F – Length, Perimeter and Area

## Pages 1–2

- 1a cm  
b mm  
c m  
d cm  
e m  
f mm

2 Answers will vary.

- 3a 50  
b 30  
c 90  
d 70  
e 110  
f 150

4a 5

- b 2  
c 22.3  
d 1.5  
e 15.6  
f 49.5

5a 3

- b 5  
c 2.5  
d 9  
e 20  
f 45.5

6a 1

- b 5  
c 4.5  
d 0.5

## Pages 3–4

- 1a 70  
b 150  
c 140  
d 0.5

- 2 ladybird;  
fridge;  
door;  
giraffe;  
tree;  
flagpole

Name	Height of the Clown on Stilts		
Peter	3 m 30 cm	330 cm	3.3 m
Sara	4 m 15 cm	415 cm	4.15 m
Omar	3 m 64 cm	364 cm	3.64 m
Julia	3 m 97 cm	397 cm	3.97 m
Heba	4 m 9 cm	409 cm	4.09 m

- a Omar  
b 6 cm  
c 85 cm  
d Answers will vary.

## Pages 5–6

- 1a m  
b km  
c m  
d km  
e km  
f m

- 2a 2  
b 5  
c 8  
d 1.5  
e 3.645  
f 1.747

- 3a 3,000  
b 7,000  
c 4,000  
d 500  
e 3,700  
f 8,200

- 4a 2 km or 2,220 m  
b 0.58 km or 600 m  
c 3.2 km or 3,100 m

4d 0.75 km or 0.79 km

e 560 m or 0.565 km

f 5.5 km or 5,600 m

5a 300 km or 2,500 m

b 0.85 km or 800 m

c 1,900 m or 2.9 km

d 1.58 km or 1,600 m

e 855 m or 0.875 km

f 7.25 km or 7,200 m

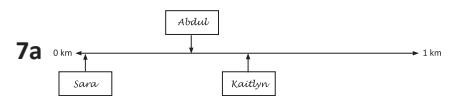
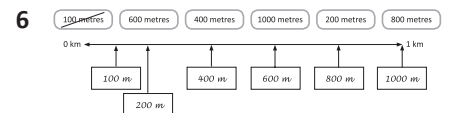

c  $0.25 \text{ km} + 3 \text{ km} + 4 \text{ km} = 7,250 \text{ m}$

## Page 7

- 1a 1  
b 10  
c 1.8  
d 16  
e 4.5  
f 180

- 2a 5 miles  
b 7 pints  
c 10 store  
d 4 inches

# Series F – Length, Perimeter and Area

## Page 8

### What to do

Observe students.

## Page 9

a  $60 \times 8 \text{ mm} = 480 \text{ mm}$  or 48 cm

b  $5 \text{ m} = 500 \text{ cm}$   
 $500 \text{ cm} - 150 \text{ cm} = 350 \text{ cm}$

c  $1 \text{ m} = 1,000 \text{ mm}$   
 $1,000 \text{ mm} \div 20 \text{ mm} = 50 \text{ pieces}$

d  $52 \text{ weeks in a year} \times 2$   
 $= 104 \text{ mm}$  or 10.4 cm

e  $0.75 \text{ m} + 0.5 \text{ m} + 0.75 \text{ m}$   
 $= 2 \text{ m}$  of sherbet stick  
 $2 \times \text{£}2 = \text{£}4$

## Pages 10–11

1a 2.123

b 4.235

c 2.245

d 5.235

e 8.145

f 8.023

g 0.835

h 0.593

2a 3,600

b 2,800

c 600

d 9,300

e 8,200

f 7,100

g 5,600

h 200

i 100

3a 0.98

b 1.572

c 0.712

d 1.962

e 2.817

4 Day 1: 200

Day 2: 358

Day 3: 145

Day 4: 173

Day 5: 173

Day 6: 504

Day 7: 232

5 1,785

## Pages 12–13

1a 400

b 800

c 700

d 1,000

e 800

f Teacher check.

2a 3

b 8

c 8

3a–c Teacher check.

4 6, 15, 45, 12, 18, 27, 30, 24, 36, 21

5 30, 60, 90, 42, 72, 54, 66, 12, 48, 36

6a 40

b 20

c 40

d 130

## Page 14

### What to do

Observe students.

### What to do next

Answers will vary.

## Page 15

### What to do

Answers will vary.

### What to do

Answers will vary.

### What to do next

Answers will vary.

## Pages 16–17

1a 12

b 14

c Teacher check.

2a 18

b 16

c 12

d 28

e 36

3a 20

b 18

c 16

d 30

e 32

4 4 cm; 10 cm; 6 cm; 5 cm

## Pages 18–19

1a 170 cm

b 440 cm

c 6.6 m

d 3.4 m

e 22 m

f 56m

g 48 m

h 28 m

2a 24

b 20

c 20

3 Playground B;

The perimeter of Playground B is smaller than the perimeter of Playground A.

Playground A = 36 m

Playground B = 33 m

## Pages 20–21

1a–d Teacher check.

2a, b Teacher check.

# Series F – Length, Perimeter and Area

## Pages 20–21

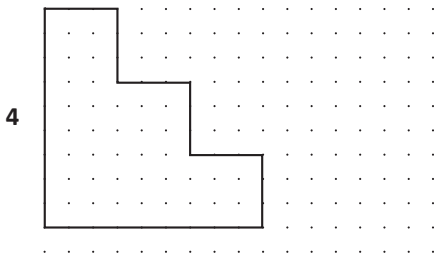
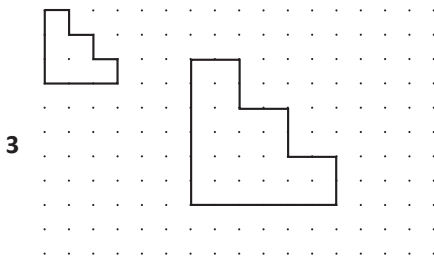

## Page 22

- a 1,200 cm or 12 m  
 b Length = 3 m  
 Width = 50 cm  
 c  $1,160 \text{ m} \times 3 = 3.48 \text{ km}$   
 d  $20 \times \text{£}55.50 = \text{£}1,110$

## Page 23

- 1 Answers will vary.  
 Sample answer:  
 $3 \times 2$  rectangle  
 shaded.

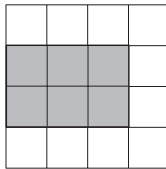

- 2a 4  
 b 2  
 c 4  
 3a 15  
 b 20  
 c 18  
 d No

## Page 24

- 1a Answers will vary.  
 b Teacher check.; Yes  
 2a–e Answers will vary.

## Page 25

- 1a 24  
 b 16

- 1c 4  
 d 10  
 e 32  
 f 6

- 2a 5 m  
 b 2 m  
 c 3 m

## Page 26

- 1a  $21 \text{ m}^2$   
 b  $70 \text{ cm}^2$   
 c  $2,000 \text{ m}^2$   
 d  $48 \text{ cm}^2$   
 e  $17 \text{ m}^2$   
 f  $112 \text{ cm}^2$

- 2 Teacher check.

## Page 27

- 1a 3  
 b 2.5  
 c 1.44  
 d 6  
 e 4.5  
 f 6

- 2 1 Ireland  
 2 Portugal  
 3 Greece  
 4 United Kingdom  
 5 Italy  
 6 Germany  
 7 Spain  
 8 France

## Pages 28–29

- 1a  $P = 20 \text{ cm}$   
 $A = 16 \text{ cm}^2$   
 b  $P = 16 \text{ cm}$   
 $A = 16 \text{ cm}^2$   
 c  $P = 12 \text{ cm}$   
 $A = 9 \text{ cm}^2$   
 d  $P = 14 \text{ cm}$   
 $A = 12 \text{ cm}^2$

- 2 Answers will vary.  
 3 Answers will vary.  
 4 Teacher check.  
 5 Teacher check.

## Page 30

- a The side of each square must be 3 cm.  
 $24 \times 3 = 72$   
 Total perimeter is 72 cm  
 b The side of each square must be 6 cm.  
 There are 34 sides.  
 $34 \times 6 = 204$   
 Total perimeter is 204 cm.  
 c If the area is  $336 \text{ cm}^2$ , the length of  
 the large rectangle must be 28 cm.  
 The width of a small rectangle must  
 be 4 cm, since  $2 - 12 = 16$  and  
 $16 \div 4 = 4$

## Page 31

### What to do

- a 32; 8  
 b 18  
 c 15

## Page 32

### What to do

- a 50  
 b 18  
 c 63  
 d 50  
 e 84  
 f 101

Circle b

Cross f

### What to do next

Teacher check.

# Units of length

Name \_\_\_\_\_

1 Write the measurement that the arrows are pointing to:

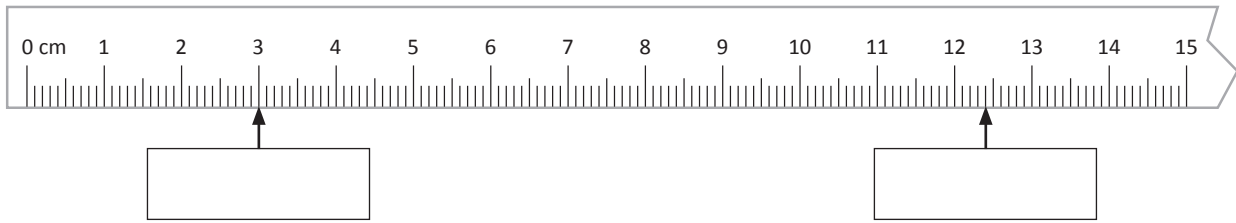

2 Convert into centimetres:

- a 50 m = \_\_\_\_\_ cm    b 8 m = \_\_\_\_\_ cm    c 11.2 m = \_\_\_\_\_ cm    d 1.2 m = \_\_\_\_\_ cm

3 Convert into millimetres:

- a 45 cm = \_\_\_\_\_ mm    b 7 cm = \_\_\_\_\_ mm    c 12 cm = \_\_\_\_\_ mm    d 110 cm = \_\_\_\_\_ mm

4 Convert into metres:

- a 500 cm = \_\_\_\_\_ m    b 7,500 cm = \_\_\_\_\_ m    c 329 cm = \_\_\_\_\_ m    d 2,000 cm = \_\_\_\_\_ m

5 Order these lengths from shortest to longest:

220 mm, 200 cm, 1 m, 2.35 m, 532 cm, 2.35 cm

6 Draw a line between the metric measurement and its approximate imperial equivalent:

0.6 l	6.5 kg	2.5 cm	1.6 km	90 cm	30 g	30 cm	0.5 kg
1 yard	1 foot	1 inch	1 ounce	1 pint	1 pound	1 stone	1 mile

Skills	Not yet	Kind of	Got it
• Measures and records length in different units			
• Converts between cm, mm and m			
• Orders lengths of different units			
• Understands approximate equivalents of metric and imperial measurements			

# Travelling far

Name \_\_\_\_\_

**1 Convert into kilometres:**

a 5,000 m = \_\_\_\_\_ km

b 80 m = \_\_\_\_\_ km

c 112 m = \_\_\_\_\_ km

d 400 m = \_\_\_\_\_ km

**2 Convert into metres:**

a 45 cm = \_\_\_\_\_ m

b 14 km = \_\_\_\_\_ m

c 7 km = \_\_\_\_\_ m

d 7.8 km = \_\_\_\_\_ m

**3 Mali rode her bike 700 metres to the shops. She then rode the same distance back again. How many kilometres did she ride her bike for in total?**

**4 Jack walks roughly 5 km/h. He walks from school to the corner shop (1,200 m), from the shop to his friend's place (3,433 m), and then home (146 m). Assuming he stops at the shops and his mate's place only briefly, can he do this trip in less than an hour? Show your working out.**

**5 Round each line to the nearest cm and use the scale to calculate the following distances:**

a E to B \_\_\_\_\_

b D to E \_\_\_\_\_

c C to B \_\_\_\_\_

d If you travel at an average speed of 70 km/h, how long would it take you to get from Point A to Point E (via points B, C and D)? Circle the best answer:

6 hours      2 hours      3 hours

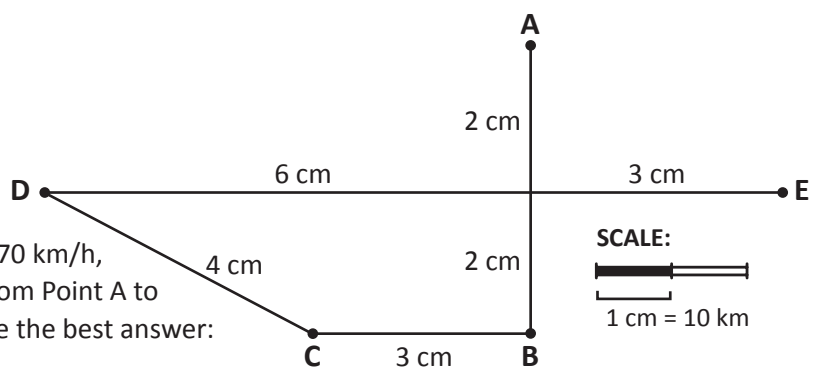

Skills	Not yet	Kind of	Got it
• Converts between metres and kilometres			
• Solves simple speed and distance problems			
• Interprets scales to calculate distances			

# Perimeter

Name \_\_\_\_\_

- 1 Draw a square with a perimeter of 8 cm. Label the length of each side.

Draw a rectangle with a perimeter of 12 cm. Label the length of each side.

- 2 Fill in the missing side lengths and find the perimeters of these symmetrical shapes\*:

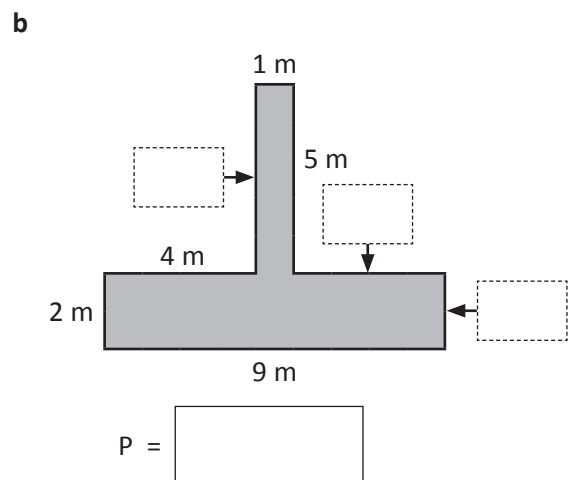
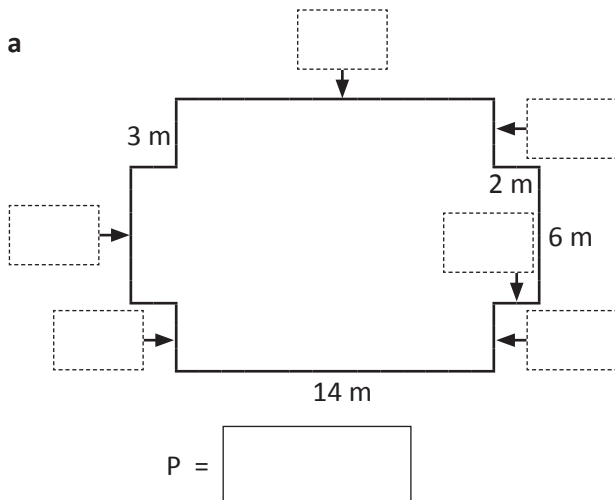

\*Not drawn to scale.

- 3 Complete this table. All shapes are regular.

Length of each side		2.5 cm		6 cm
Perimeter	16 cm		25 cm	

Skills	Not yet	Kind of	Got it
• Measures the perimeter of shapes			
• Creates shapes with specified perimeters			
• Uses understanding of perimeter to calculate side lengths			



1 What is the area of each shaded shape? Each square has an area of  $1 \text{ cm}^2$ .

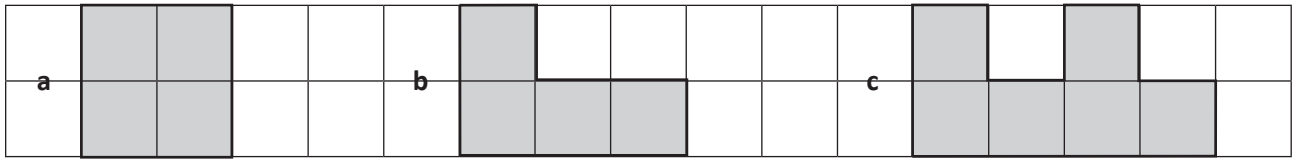

Area =   $\text{cm}^2$

Area =   $\text{cm}^2$

Area =   $\text{cm}^2$

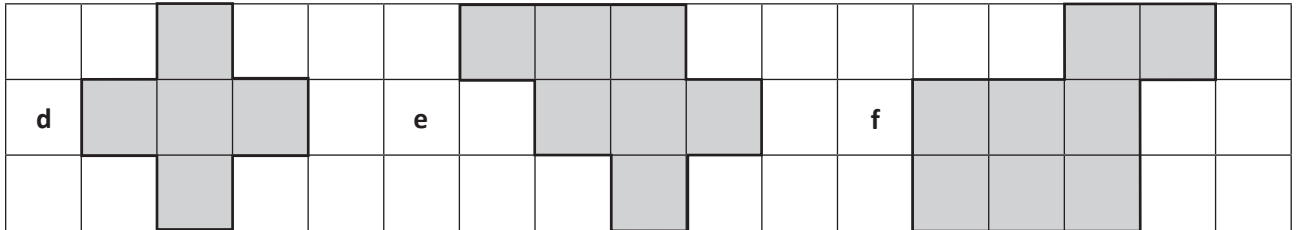

Area =   $\text{cm}^2$

Area =   $\text{cm}^2$

Area =   $\text{cm}^2$

2 Create 2 different shapes with an area of  $18 \text{ cm}^2$ :

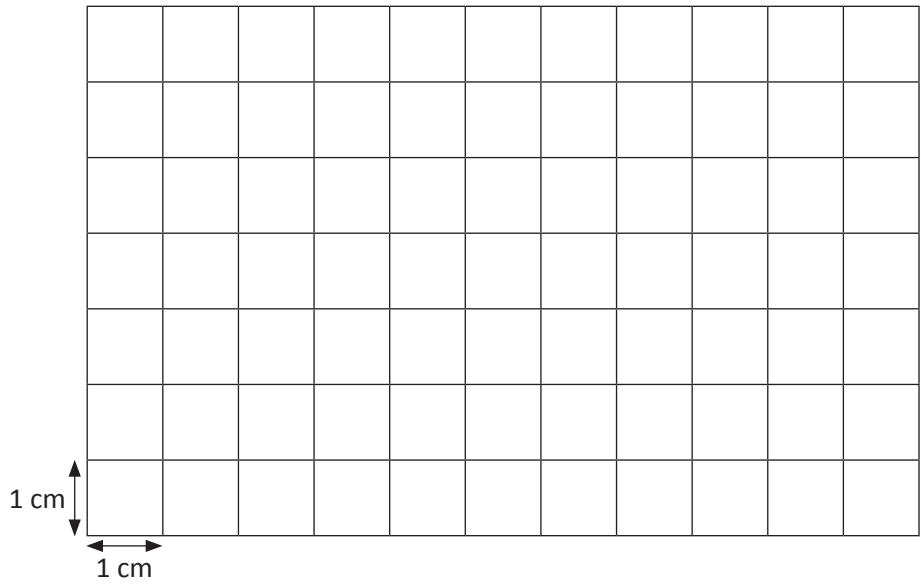

3 Find the area of:

a A rectangle measuring  $6 \text{ cm} \times 5 \text{ cm}$

b A swimming pool measuring  $25 \text{ m} \times 4 \text{ m}$

c A box measuring  $12 \text{ cm} \times 9 \text{ cm}$

d A phone measuring  $4.5 \text{ cm} \times 10 \text{ cm}$

4 Find the area of these composite shapes:

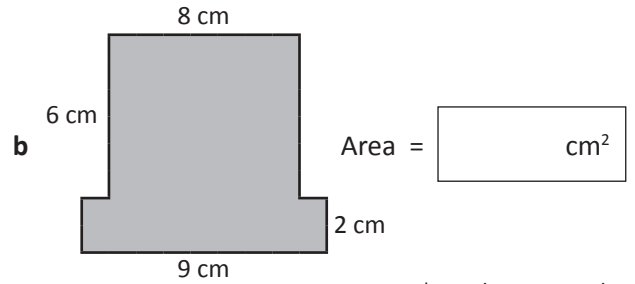
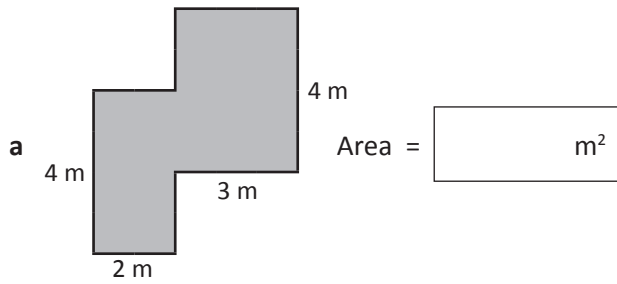

*\*Not drawn to scale.*

5 Would you choose cm<sup>2</sup>, m<sup>2</sup>, ha or km<sup>2</sup> to measure the area of the following?

a this page

b Africa

c a classroom

d an iPod

6 Create 2 shapes each with a perimeter of 10 cm but with different areas:

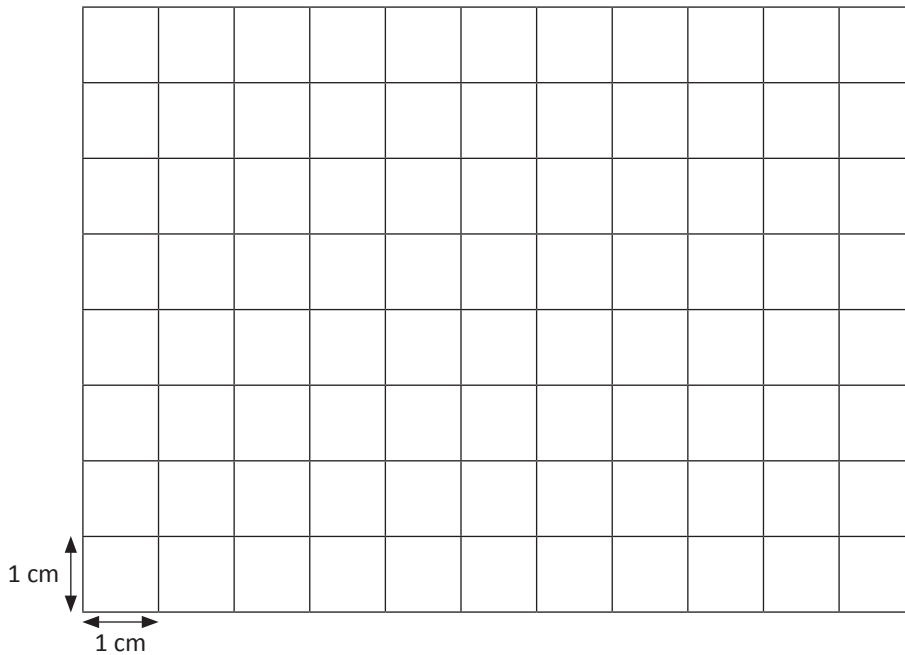

Skills	Not yet	Kind of	Got it
• Finds the area of shapes using grids			
• Uses formula $L \times W$ to find area of rectangles			
• Finds the area of irregular and composite shapes			
• Makes appropriate unit choices for measuring			
• Recognises shapes can have same perimeters but different areas			

## Series F – Length, Perimeter and Area – Student Progress Record

Name \_\_\_\_\_ Class \_\_\_\_\_ Date \_\_\_\_\_

What went well: \_\_\_\_\_

---

---

---

What I need to improve: \_\_\_\_\_

---

---

---



## Series F – Length, Perimeter and Area – Student Progress Record

Name \_\_\_\_\_ Class \_\_\_\_\_ Date \_\_\_\_\_

What went well: \_\_\_\_\_

---

---

---

What I need to improve: \_\_\_\_\_

---

---

---

# Series F – Length, Perimeter and Area

## ASSESSMENT ANSWERS

### Page 4

1 3 cm; 12.4 cm

2a 5,000

b 800

c 1,120

d 120

3a 450

b 70

c 120

d 1,100

4a 5

b 75

c 3.29

d 20

5 2.35 cm, 220 mm, 1 m, 200 cm,  
2.35 m, 532 cm

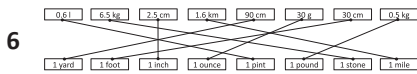

### Page 5

1a 5

b 0.08

c 0.112

d 0.4

2a 0.45

b 14,000

c 7,000

d 7,800

3  $0.7 \text{ km} + 0.7 \text{ km} = 1.4 \text{ km}$

4  $1.2 \text{ km} + 3.433 \text{ km} + 0.146 \text{ km}$   
 $= 4.779 \text{ km}$ , which is less than  
5 km, so YES Jack can do it in less  
than an hour.

5a 50 km

b 90 km

c 30 km

d 3 hours

### Page 6

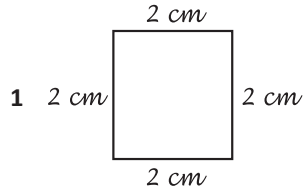

Answers will vary.

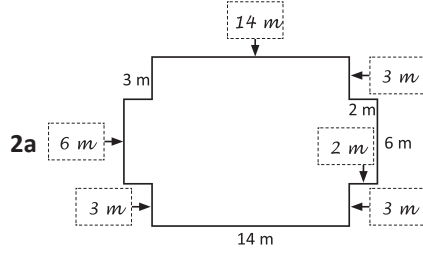

P = 60 m

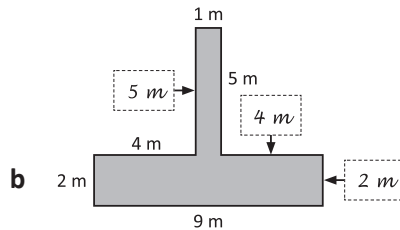

P = 32 m

3 Length of each side: 4 cm; 5 cm

Perimeter: 20 cm; 36 cm

### Pages 7–8

1a 4

b 4

c 6

d 5

e 7

f 8

2 Answers will vary.

Sample answers:

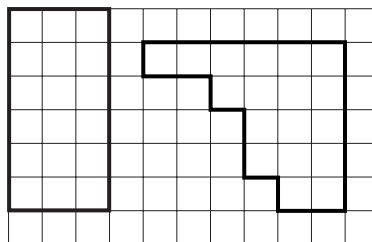

3a  $30 \text{ cm}^2$

b  $100 \text{ m}^2$

c  $108 \text{ cm}^2$

d  $45 \text{ cm}^2$

4a 20

b 60

5a  $\text{cm}^2$

b  $\text{km}^2$

c  $\text{m}^2$

d  $\text{cm}^2$

6 Answers will vary.

Sample answers:

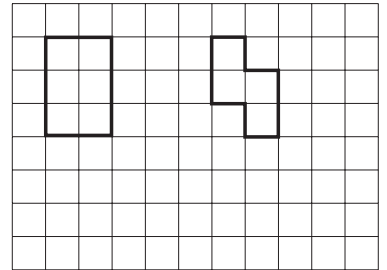

## Series F – Length, Perimeter and Area

Topic	Reference	Strand	Objective
<b>Units of Length</b>	5M9b	Measurement	Use all four operations to solve problems involving measure (e.g. length) using decimal notation including scaling.
<b>Travelling Far</b>	5M9b	Measurement	Use all four operations to solve problems involving measure (e.g. length) using decimal notation including scaling.
<b>Perimeter</b>	5M7a	Measurement	Measure and calculate the perimeter of composite rectilinear shapes in centimetres and metres.
<b>Area</b>	5M7b	Measurement	Calculate and compare the area of squares and rectangles including using standard units, square centimetres (cm <sup>2</sup> ) and square metres (m <sup>2</sup> ) and estimate the area of irregular shapes.